

TCR-1000 AIR HOIST

STANDARD FEATURES

- ▷ Toku rotary vane motor
- ▷ ATEX zone 2 specification
- ▷ Robust epicycle gearbox
- ▷ Failsafe automatic internal disc brake
- ▷ Mechanical upper & lower switches
- ▷ Cast steel housing
- ▷ Internal silencing down to 83 dB(A)
- ▷ Alloy safety swivel hooks with safety catch
- ▷ Load chain 7 x 21mm of European manufacture to EN818-7
- ▷ Automatic load limiter

AVAILABLE OPTIONS

- ▷ Marine specification
- ▷ Special paint systems
- ▷ Corrosion protection
- ▷ ATEX zone 1 specification
- ▷ Chain collectors (PVC, galvanised or stainless steel)
- ▷ Air Service units
- ▷ Festoon systems
- ▷ Radio control
- ▷ Main air shut off valve

MODEL	WLL	LIFTING SPEED WITH LOAD	LIFTING SPEED WITHOUT LOAD	LOWERING SPEED WITH LOAD
TCR-1000	1000 kg	6.0 m/min	11.3 m/min	10.3 m/min
	AIR CONSUMPTION LIFTING	AIR CONSUMPTION LOWERING	AIR CONNECTION	MINIMUM HOSE DIA.
TCR-1000	25 l/sec	28 l/sec	1/2" BSP	1/2" HOSE
	CHAIN FALLS	WORKING PRESSURE	WEIGHT WITH 3M HOL	ADDITIONAL METRE HOL
TCR-1000	1	6 bar	34.0 kg	1.1 kg

C = CORD CONTROL PE = PENDANT

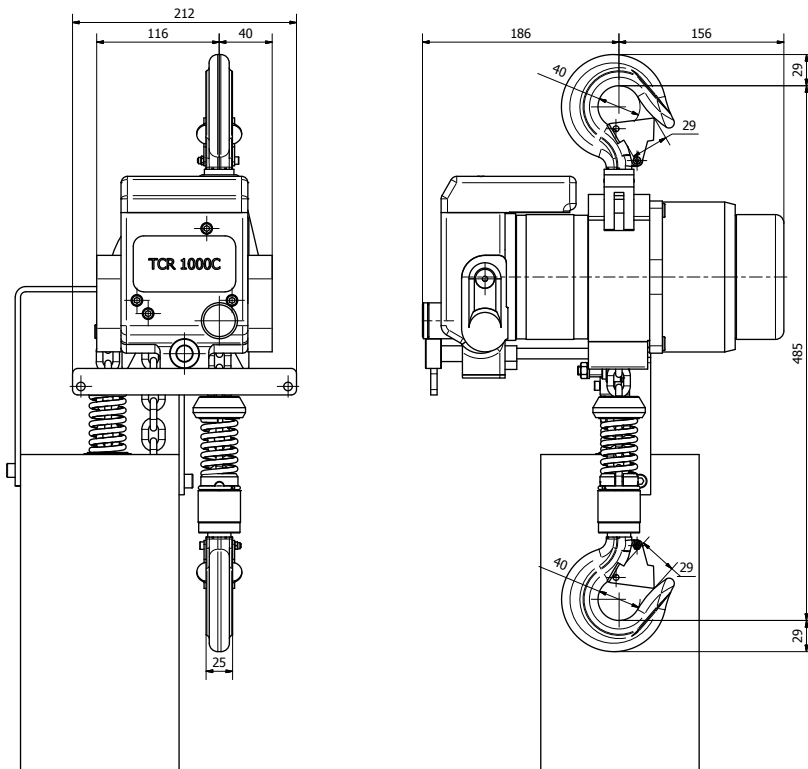

All measurements are in mm
Information subject to change without notice

Image for illustration purposes only



ATEX ZONE 2 AS STANDARD

FIRST INTEGRATED SOLUTIONS

First Integrated House, Broadfold Road
Bridge of Don, Aberdeen
United Kingdom, AB23 8EE

T: +44 (0) 1224 787585
E: sales@firstintegrated.co.uk
W: www.firstintegrated.co.uk